



# KIDDYGUARD™ AVANT

[www.kiddyguard.com](http://www.kiddyguard.com)

Lascal®

Serial Number

Dear Customer, Thank you for choosing a KiddyGuard™ Avant from Lascal. We hope you are delighted with your purchase and enjoy the protection it gives small children.

KiddyGuard™ Avant is a safety gate designed for children up to 24 months of age. KiddyGuard™ Avant protects door or stair openings which are up to 130cm (51 inches) wide.

## Index

---

Warnings and Safety Information .....	3
Parts of the KiddyGuard™ Avant .....	4
Location for Use .....	5
Attaching the Gate Housing .....	6
Attaching the Locking Strip .....	7
How to Operate .....	8
Accessories .....	9
Material Composition .....	10
Cleaning Instruction .....	10
Warranty .....	10
Safety Standards and Tests .....	10
Other Lascal Products .....	11-12
Contact Information .....	13-14
Product Registration Card.....	15-16

**IMPORTANT !**  
**READ AND FOLLOW THESE INSTRUCTIONS**  
**CAREFULLY AND KEEP FOR FUTURE REFERENCE**



**WARNING !**

**SAFETY INFORMATION**

This product complies with both European Standard EN 1930:2000 and US Safety Standard ASTM F1004-00 and the warnings are in accordance with these Standards.

**WARNING** - Incorrect Installation can be dangerous.

**WARNING** - Do not use the safety barrier if any components are damaged or missing.

**WARNING** - The safety barrier must not be fitted across windows.

This safety barrier is for domestic use only.

To prevent serious injury or death, securely install and position the KiddyGuard™ Avant and use it according to these instructions.

The KiddyGuard™ Avant should not be subject to mechanical damage e.g. hitting it with sharp, hard objects or scratching from pet claws or pulling up or down on it, as this will cause damage.

When fitted in place, check the barrier to ensure that it is properly fixed and secure.

The KiddyGuard™ Avant has both manual and automatic locking system. However, ensure that the locking mechanism is securely engaged every time that you close the stairgate.

The KiddyGuard™ Avant general condition and safety mechanism should be checked periodically, with particular reference to the security of attachments and operation of the locking device, in accordance with these instructions.

Do not allow adults, children or pets to climb over or under the safety barrier, it may damage or dislodge the gate and cause injury.

Stop using the barrier if the child is capable of climbing over or dislodging it.

Intended for use with children from 6-24 months of age. This product will not necessarily prevent all accidents. Never leave your child unattended.

Additional and replacement parts should only be obtained from the Manufacturer or Distributor.

# KIDDYGUARD™ AVANT PARTS

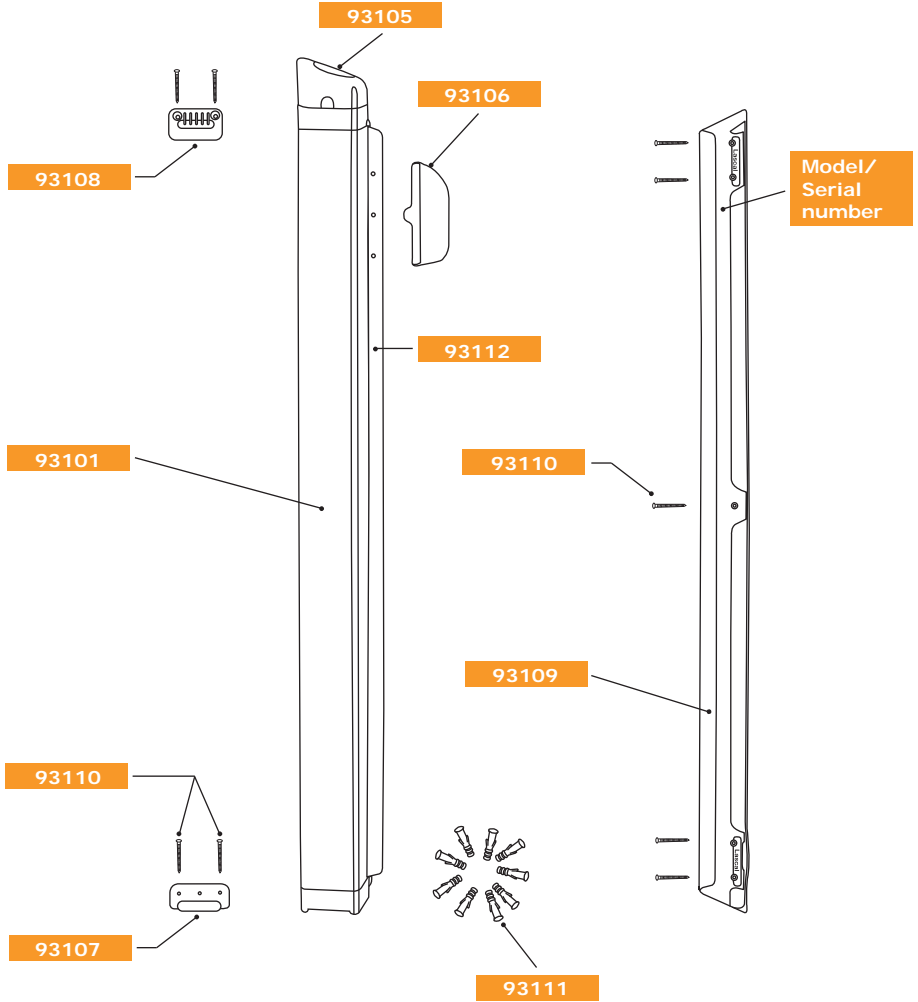

Part No.	Quantity	Description
93101	1	Gate Housing
93105	1	Top Cover (attached to gate housing - removable)
93106	1	Handle
93107	1	Bottom Bracket
93108	1	Top Bracket
93109	1	Locking Strip
93110	9	Wood Screws
93111	9	Rawl Plugs/Plastic Anchors
93112	1	Locking Rod (attached to mesh - non removable)

## LOCATIONS FOR USE

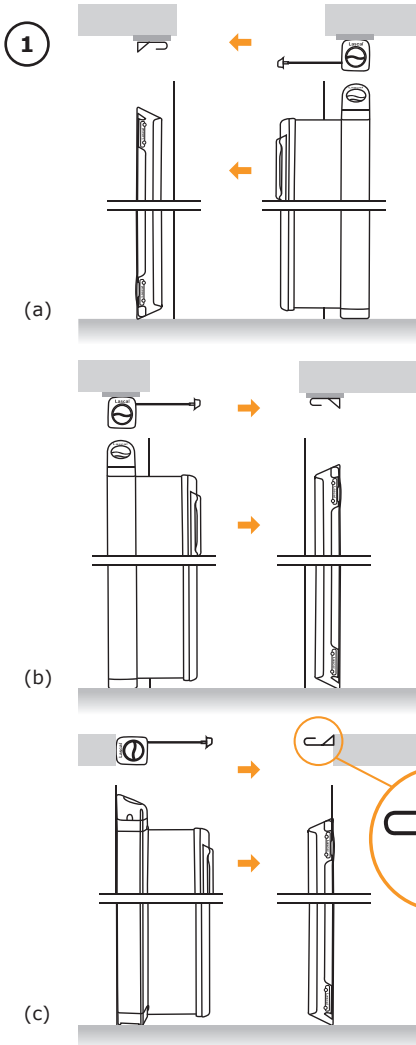

### 1. Decide whether the KiddyGuard™ Avant will attach.

a) To the wall to the right and in front of the opening/stairways. Fig 1a.

OR

b) To the wall to the left and in front of the opening/stairway. Fig 1b.

OR

c) Within the opening/stairway, to either the right/left. Fig 1c.

### NOTE:

The Locking Strip should be mounted flush to the edge and with the hook facing away from the opening.

### 2. Use at top or bottom of stairs

a) TOP of stairs - Base of KiddyGuard™ Avant must be at floor level and 15 cm/6 inches back from the top step. Fig 2a.

OR

b) BOTTOM of stairs - Base of KiddyGuard™ Avant must be positioned at the front of the lowest tread possible. Fig 2b.

### WARNING:

The position of the safety barrier in relation to the stairs may have an adverse effect on your child's safety.

Please note the following:

- If the safety barrier is used at the top of the stair to prevent the child from falling down the stairs, it must not be placed on any stair below the level of the top stair.

- If the safety barrier is used at the bottom of the stairs, to prevent the child from climbing the stairs, it must be placed on the lowest stair.

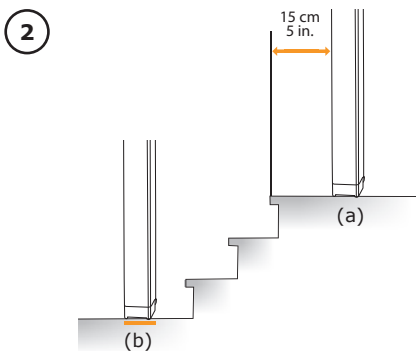

## ATTACHING THE GATE HOUSING

3

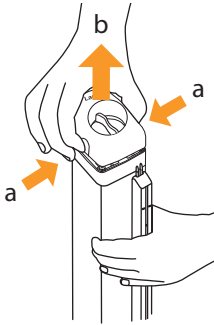

### 3. Remove the Top Cover

- Squeeze the base of the cover
- Lift

4

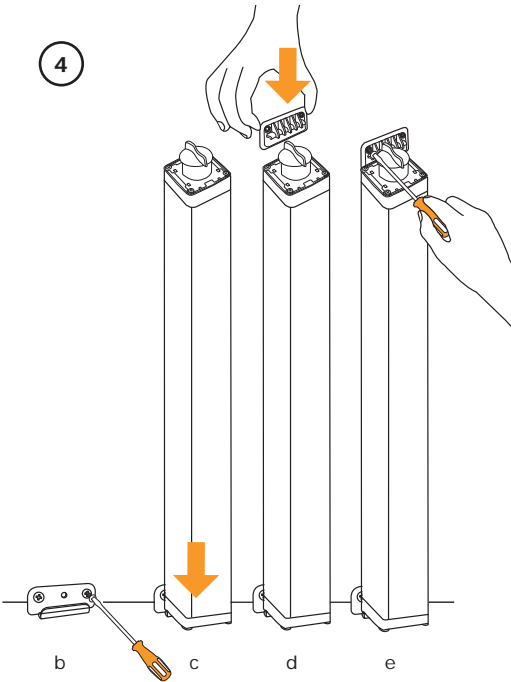

### 4. Fit the Gate Housing

- Decide position as per the options in Figure 1.
- Attach the bottom bracket flush with the floor ensuring the screw holes are aligned horizontally. When attaching to:  
Wood - Use the screws provided. Drill pilot holes before tightening the screws.  
Concrete/brick - Use the screws + rawl plugs/plastic anchors provided. Drill hole 6 mm, (1/4 in). Insert rawl plugs/plastic anchors flush with wall and then tighten screws.  
Other wall materials - use an appropriate fixing system.  
Bannister - use the Bannister Installation Kit. See Accessories.
- Slide Gate Housing onto bottom bracket.
- Position Top Bracket to the top of the Gate Housing.
- Ensure the Gate Housing is vertical and mark the locations for the screw holes. Fix the screws according to b.

Make sure that the gate is mounted **firmly and vertically**.

N.B. If there is a **Skirting/Base Board** on the wall to which the housing is to be attached, a piece of wood, the thickness of the skirting/base board will need to be positioned between the Top Bracket/Top Cover of the KiddyGuard™ Avant and the wall.

5

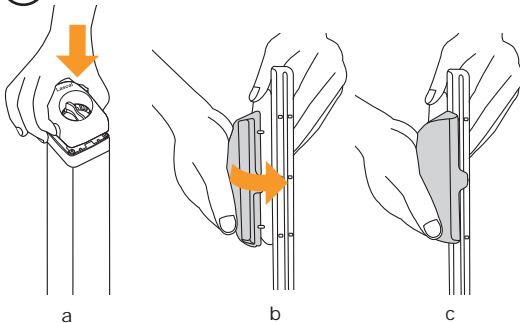

### 5. Attach Top Cover and Handle

- Push the Top Cover firmly back onto the Gate Housing, with the high side flush to the wall.
- Pull out a portion of the mesh (see Fig. 8b). Align tabs on Handle with holes on Locking Rod. (5b)
- Rotate Handle back until it snaps into place. (5c)

## ATTACHING THE LOCKING STRIP

6

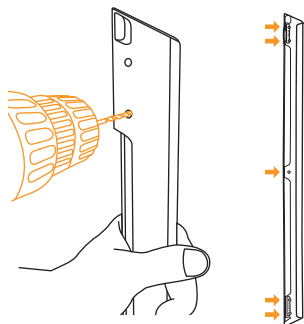

(a)

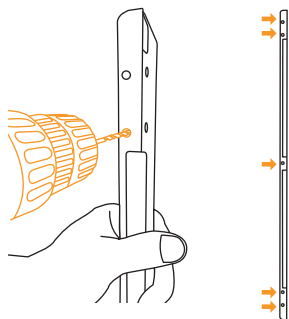

(b)

### 6. Prepare the Locking Strip

Drill five holes at the points marked on the Locking Strip according either:

- When attaching the Locking Strip TO THE WALL, as shown in Fig 1a and 1b, please follow Fig 6a to prepare the Locking Strip. Identify the five hole markers on the wide surface of the Locking Strip. Use a power drill with a 4mm, (1/6 in) drill bit and drill out the five holes.
- When attaching the Locking Strip INSIDE AN OPENING, as shown in Fig 1c, please follow Fig 6b. To prepare the Locking Strip, identify the five hole markers on the edge of the Locking Strip. Use a power drill with a 4mm, (1/6 in) drill bit to drill out the five holes

7

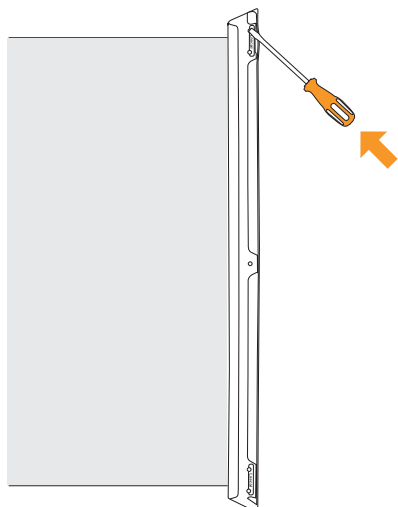

### 7. Attach the Locking Strip

Release and pull out the gate, see "How to operate", Fig 8b.

Hook the Locking Rod onto the Locking Strip, and hold it against the wall/bannister against which it is to be mounted. It is essential that the mesh is evenly stretched across the opening, with no sagging at either the top or bottom.

Attach the Locking Strip to the wall by marking through the holes of the Locking Strip to identify where screw holes should be drilled. See Fig. 4 to determine how to screw the Locking Strip to different wall materials.

If there is a **Skirting/Base Board** on the wall to which the Locking Strip is to be attached, a piece of wood, the thickness of the **Skirting/Base Board**, will need to be positioned between the Locking Strip and the wall, at the top of the Locking Strip.

8

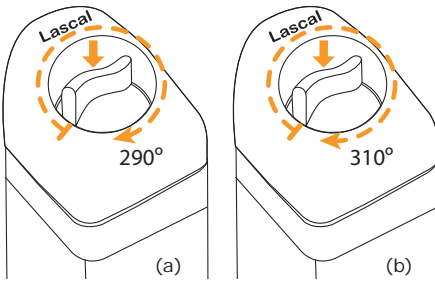

## 8. Locking System

### Locking/Unlocking options:

- Timed lock** - Push and turn the locking button clockwise up to 290°. You will have a few seconds to draw the gate open and closed before it locks. TIP: The more you turn the button up to 290°, the more time you will have to close or open the gate.
- Manual lock** – Push and turn the locking button clockwise through to 310°. The gate will be permanently free to open or close, with no time limitation. The gate will not lock until you turn the locking button anti-clockwise, back beyond the 290° position for timed locking or back to 0° for immediate locking.

The KiddyGuard™ Avant is easy to operate single-handed.

9

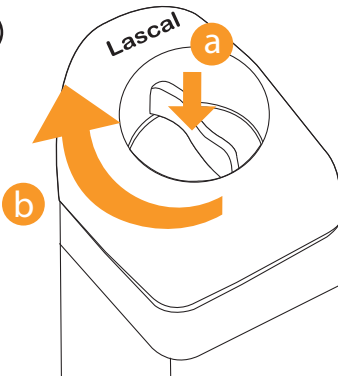

## 9. To close the KiddyGuard™ Avant

- Push down the button on the top of the gate.
- Turn the button clockwise. see Fig 8.
- Use the Handle to pull the gate across and hook it onto the Locking Strip. see Fig 10.

### IMPORTANT

AFTER CLOSING THE KIDDYGUARD™ AVANT, ALWAYS CHECK THAT THE GATE IS LOCKED BY PUSHING GENTLY AGAINST THE MESH.

10

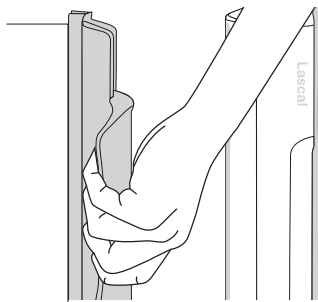

## 10. To open the KiddyGuard™ Avant

Release the gate by repeating the operations 9a and 9b. Unhook the gate and let it roll up.

### IMPORTANT

CONTINUE TO HOLD THE HANDLE WHILE THE GATE ROLLS UP.

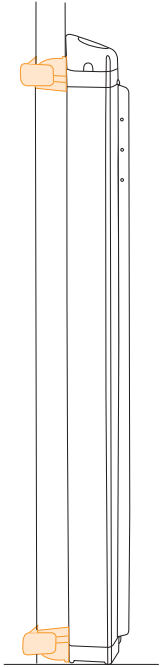

BIK Gate Housing

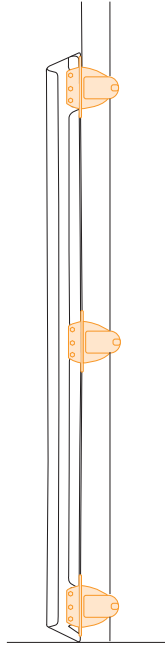

BIK Locking Strip

### Bannister Installation Kit

The Gate Housing and the locking strip can be attached directly to the bannister by using one or both of the following bannister kits:

#### Bannister Installation Kit (BIK) for the Gate Housing.

Item No. 12560

#### Bannister Installation Kit (BIK) for the Locking Strip.

Item No. 12561

### Bannister Dimensions:

Both Bannister Installation Kits can be used on round or square bannisters with the following dimensions.

#### Circular bannisters:



∅

Minimum  
14mm  
7/16"

Maximum  
50mm  
2"

#### Square bannisters:



Minimum  
14 x 14mm  
7/16" x 7/16"

Maximum  
50 x 50mm  
2" x 2"

## MATERIAL COMPOSITION OF THE KIDDYGUARD™ AVANT

The plastic parts are made of Polyamide (PA6) Polyoxymethylene (POM), Polypropylene (PP) and Polyester (PE). The body of the KiddyGuard™ Avant is made of Aluminium. The materials are chosen for their strength and resistance. All parts are non-toxic and can be recycled. The mesh of the KiddyGuard™ Avant is flameproof.

## CLEANING INSTRUCTIONS

All parts of the KiddyGuard™ Avant can be cleaned with a mild, liquid household detergent on a damp cloth. Do not use chlorine or abrasive powder.

## ONE YEAR WARRANTY

Your KiddyGuard™ Avant is guaranteed to be free from manufacturing defects for a period of one year from date of purchase, when used under normal conditions and in compliance with this Owner's Manual. This warranty extends only to the original retail purchaser and is only valid when supplied with proof of purchase.

## SAFETY STANDARDS AND TESTS

Your KiddyGuard™ Avant meets or exceeds the following standards  
U.S. Safety Standard ASTM F1004-00 and  
European Safety Standard EN 1930:2000

All components are tested and meet the standard for  
children products according to CPSIA (USA) and REACH (EU)

## LASCAL M1 CARRIER™

### The Ultimate Baby Carrier

The Lascal M1 Carrier™ is the next generation of baby carriers with a sporty and fashionable look for today's parent. Using the latest high-tech ventilated fabrics dramatically increases the comfort for both baby and parent. Super soft and naturally anti-bacterial Bamboo fabric is perfect for the removable Top Cover and for the leg and arm openings, that come in contact with baby's skin.

## Lascal® M1™ Carrier



## BUGGYBOARD®-MAXI

Premium design fits 99% of all pushchairs / strollers to provide a safe and fun platform for your toddler to ride.

Packed with ground breaking design features, the state of the art MAXI™ boasts an EXTRA LARGE anti slip platform with in-built suspension for the ultimate in ride comfort; bigger wheels to make the going easier over bumpy ground and to give EXTRA CLEARANCE for Mum's feet; plus side reflectors for night time visibility and the handy Lascal LIFT 'N' STORE hang up device.

Suitable for children from 2-5 years.



## BUGGYBOARD®-MINI

Compact board fits classic buggies and umbrella fold strollers.

Portable and lightweight, the MINI™ is packed with carefully thought out design features including the secure, easy to use Lascal connector mechanism; an anti slip platform with side protection frame; in-built suspension for a smoother ride and a LIFT 'N' STORE hang up device so the board can be hooked up out of the way when it is not required.

Suitable for children from 2-5 years.



**AUSTRALIA**

CNP Brands  
Derrimut VIC 3030  
Australia  
Tel. +61 3 9394 3000  
Customer Service: 1300 667 137  
E-mail: info@cnpbrands.com.au  
www.cnpbrands.com.au

**AUSTRIA**

BMK Handels-und Vertriebs GmbH  
1230 Wien  
Tel. +43 (0)1-8038767  
E-mail: info@popolini.com  
www.popolini.com

**BELGIUM**

Hebeco NV  
2960 Brecht  
Belgium  
Tel. +32 (0)3 330 12 12  
E-mail: info@hebeco.be  
www.hebeco.be

**CANADA**

Regal Lager, Inc.  
Kennesaw GA, 30144,  
U.S.  
Ph. 800-593-5522  
E-mail: info@regallager.com  
www.regallager.com

**CHINA-SHANGHAI**

彩趣贸易(上海)有限公司  
上海徐汇区龙华西路585号  
华富大厦A栋16楼01室  
电话: +86 21 6361 0232  
+86 21 6468 1095  
传真: +86 21 6469 8968

**CYPRUS**

Xenios Demetriades & Son Ltd  
1070 Nicosia  
Ph. +357 96620137  
E-mail: gkzorpas@cytanet.com.cy  
www.demetriades.com.cy

**CZECH REPUBLIC**

VISPA NACHOD sro  
54912 Vysokov 1  
Tel: +420 491 433 544  
E-mail: vispa@vispa.cz  
www.vispa.cz

**DENMARK**

Nord-Ideen,  
Martin Frommhagen  
23821 Wardersee,  
Germany  
Tel. +49 (0)4559/18840  
www.nordideen.de

**ESTONIA /  
LATVIA / LITHUANIA**

4kids OÜ  
Randvere tee 17-51  
74001 Haabneeme, Harjumaa  
Estonia  
Phone: +372 5309 0606  
Fax: +372 699 0304  
E-mail: info@4kids.ee  
www.4kids.ee

**FINLAND**

Britax - Pohjolan Lapset Oy  
00930 Helsingfors  
Puh. +358 (0)9 343 60 10  
E-mail: info@britax.fi  
www.britax.fi

**FRANCE**

Gamin Tout-Terrain  
75019 Paris  
Tel. +33 (0)1 42 38 66 00  
E-mail:  
info@gamin-tout-terrain.com  
www.gamin-tout-terrain.com

**GERMANY**

Nord-Ideen,  
Martin Frommhagen  
23821 Wardersee  
Tel. 04559/18840  
www.nordideen.de

**HOLLAND**

Hebeco NV  
2960 Brecht  
Belgium  
Tel. +32 (0)3 330 12 12  
E-mail: info@hebeco.be  
www.hebeco.be

**HONG KONG,  
CHINA & MACAU**

Lasca! Ltd.  
Suite 919, 9th floor, Tower 3  
China Hong Kong City  
33 Canton Road, Kowloon  
Hong Kong (SAR)  
Tel. +852 2302-1511  
E-mail: info@lasca!.com.hk  
www.lasca!.se

**HUNGARY**

Brendon Gyermekáruházak Kft.  
1138 Budapest  
Tel. 01-320-8872  
www.brendon.hu

**ICELAND**

Fifa Ltd.  
Reykjavik 110  
Ph. +354 552 25 22  
E-mail: fifa@fifa.is  
www.fifa.is

**IRELAND**

Cheeky Rascals Ltd.  
Hants. GU33 6JG UK  
Tel. +44 01730 895761  
Fax. +44 01730 897549  
E-mail: sales@cheekyrascals.co.uk  
www.cheekyrascals.co.uk

**ISRAEL**

Baby Safe  
Kibbutz Mishmarot  
P.O.B 3091  
Caesarea ind. Park 38900  
Tel. 972 54 6379349  
E-mail: ereches@babysafe.co.il  
www.babysafe.co.il

**ITALY**

Primi Sogni Srl  
24060 Telgate  
Tel. +39 (0)35/831271  
E-mail: info@primisogni.com  
www.primisogni.com

**JAPAN - 日本**

株式会社 ディーレックス  
〒541-0053  
大阪市中央区本町2丁目3番14号  
船場旭ビル5F  
Tel: 06-6271-7501  
E-mail: smart@t-rexbaby.co.jp  
www.t-smartstart.com

## CONTACT INFORMATION (K - Z)

### **T-Rex, Co. Ltd.**

Senba Asahi Bldg  
2-3-14 Honmachi  
Chuo-ku, Osaka  
#541-0053

### **KOREA**

Penta Zone Inc.  
Seoul, Korea  
Tel: +82-2-599 0860  
E-mail: pentaz@choi.com  
Sole Distributor for  
Lascal m1 carrier

### **Zero to Seven Co.,Ltd**

Hanmi Bldg 11F, 1,  
Gongpyeong-dong,  
Jongro-gu, Seoul, #110-160  
Korea  
Tel: 82-1588-8744  
Fax: 82-2-740-3197  
E-mail: mallmaster@maeil.com  
www.0to7.com  
Sole Distributor for Buggy Board,  
Kiddy Board and Kiddy Guard

### **LUXEMBOURG**

Hebeco NV  
2960 Brecht  
Belgium  
Tel. +32 (0)3 330 12 12  
E-mail: info@hebeco.be  
www.hebeco.be

### **MALAYSIA**

Infantree  
Singapore, 787601  
Tel. 454 1867  
E-mail: suzanne@infantree.net  
www.infantree.net

### **MALTA**

Rausi Co. Ltd  
San Gwann, SGN 09  
Tel. +356 21 445654  
E-mail: info@rausi.com.mt  
www.rausi.com.mt

### **NORWAY**

Norske Servicesystemer AS  
N-3511 Honefoss  
Tel: +47 32 124944  
E-mail: post@servicesystemer.no  
www.servicesystemer.no

### **POLAND**

Tootiny  
ul. Trzebiatowska 16  
60-432 Poznan, Poland  
Tel: +48-0-61-8499 261  
E-mail: mail@tootiny.com  
www.tootiny.com

### **PORTUGAL**

B.B. Aventurero, S.L.  
Progreso, 35, 08850 Gava  
Barcelona, Spain  
Tel: +34 93 637 08 44  
E-mail:  
infor@elbebeaventurero.com  
www.elbebeaventurero.com

### **RUSSIA - Россия**

107553 Москва  
1-ая Пугачевская ул. влад.17  
Тел.(495)161 29 45,  
(495)161 25 91, (495)161 27 48  
E-mail: maxi-cosi@carber.ru  
www.carber.ru

### **Carber Poriferra**

Moscow 107553  
Tel. +7 (495) 161 29 45

### **SINGAPORE**

Infantree Pte Ltd  
Singapore, 787601  
Tel. +65 6454 1867  
E-mail: suzanne@infantree.net  
www.infantree.net

### **SLOVENIA**

MAMI d.o.o.  
1236 Trzin  
Tel. 01-5623350  
E-mail: mami@siol.net  
www.mami.si

### **SPAIN**

B.B. Aventurero S.L.  
Progreso 35, 08850 Gava  
Barcelona, Spain  
Tel: +34 93 637 08 44  
E-mail:  
infor@elbebeaventurero.com  
www.elbebeaventurero.com

### **SWEDEN**

Carlo i Jönköping AB  
556 52 Jönköping  
Tel. +46 (0)36-690 00  
E-mail: info@carlobaby.com  
www.carlobaby.com

### **SWITZERLAND**

BAMAG Babyartikel und Möbel AG  
CH-8320 Fehraltorf  
Tel. +41 (0)44 954 88 00  
E-mail: info@babybamag.ch  
www.babybamag.ch

### **TAIWAN**

Toppin 886-2-87924158  
E-mail: topping2@ms21.hinet.net  
www.babybus.com.tw

### **THAILAND**

Thai Soonthorn International  
Trading Co., Ltd.  
316 Soi Taksin 19, Taksin Road,  
Bukkalo, Thonburi, Bangkok 1060  
Tel: +662 2891891  
E-mail: info@thaisoonthorninter.com  
www.thaisoonthorninter.com

### **UNITED KINGDOM**

Cheeky Rascals Ltd.  
Hants, GU33 6JG  
Tel. +44 01730 895761  
Fax. +44 01730 897549  
E-mail: sales@cheekyrascals.co.uk  
www.cheekyrascals.co.uk

### **UNITED STATES**

Regal Lager, Inc.  
Kennesaw GA, 30144  
Ph. 800-593-5522  
E-mail: info@regallager.com  
www.regallager.com

### **VIETNAM**

Maxcare Co., Ltd  
366Xadan Str  
Dongda Dist,  
Hanoi  
Vietnam  
Ph. 0435738311  
Fax: 0435738314  
E-mail: thanh.nguyen\_hn@mrbaby.vn  
www.mrbaby.vn

## PRODUCT REGISTRATION CARD



Register your purchase at [www.lascal.se/web/register](http://www.lascal.se/web/register) or fill in and return this card to your local distributor.  
Regístrate su compra en [www.lascal.se/web/register](http://www.lascal.se/web/register) o rellene este formulario y envíelo por correo.  
Enregistrez votre achat sur [www.lascal.se/web/register](http://www.lascal.se/web/register) ou complétez et renvoyez cette carte par la poste.  
Registrieren Sie Ihren Kauf unter [www.lascal.se/web/register](http://www.lascal.se/web/register) oder füllen Sie diese Karte aus und senden Sie diese per Post.

- Eng.** Registering is the only way to guarantee that Lascal will notify you in the unlikely event we need to issue a safety notification.
- Esp.** El registrarse es la única garantía de que Lascal le notifique, si fuese necesario, la emisión de un certificado de seguridad.
- Fr.** L'enregistrement de votre achat vous garantit que Lascal vous tiendra informé dans le cas où un avis de sécurité serait publié.
- De.** Eine Registrierung ist die einzige Möglichkeit Sie im unwahrscheinlichen Falle einer Rückrufaktion informieren zu können.

.....  
Name / Nombre / Nom / Nom

.....  
Address / Dirección / Adresse / Adresse

.....  
Town / Ciudad / Ville / Ort

.....  
Country / State / Provincia / Etat / Staat      Postcode / Código postal / Code postal / Postleitzahl

.....  
Country / Pays / Pays / Land

.....  
E-mail address / E-mail / Email / e-mail adresse

.....  
Date of purchase  
Fecha de compra  
Date d'achat  
Kaufdatum

.....  
Model / Serial number  
Número de serie  
Numéro de série  
Seriennummer

The serial number can be found at Locking Strip, see page 4.

**KiddyGuard™**  
avant

Register online at [www.lascal.se/web/register](http://www.lascal.se/web/register)

## PRODUCT REGISTRATION CARD



Place  
stamp  
here

## PRODUCT REGISTRATION CARD

- Eng. To return this card by mail, please find the address of your local registration office on page 13-14, or register online at [www.lascal.se](http://www.lascal.se)
- Esp. Envíe esta tarjeta por correo, busque la dirección de su oficina en el registro de la página 13-14, o regístrese on-line en [www.lascal.se](http://www.lascal.se)
- Fr. Affranchissez cette carte et renvoyez la au distributeur de votre pays (voir liste en page 13-14, ou en ligne sur [www.lascal.se](http://www.lascal.se))
- De. Möchten Sie diese Karte per Post einschicken, finden Sie das zuständige Büro auf den Seiten 13-14, oder registrieren Sie sich unter [www.lascal.se](http://www.lascal.se).

Lascal

Please fold and seal with tape before mailing. Do not staple.  
Por favor, doble y pegue esta tarjeta antes de enviarla. No utilizar grapas.  
Plier et scotcher avant de poster. Ne pas agraffer.  
Bitte falten und mit Klebeband versiegeln. Bitte nicht tackern.

Register online at [www.lascal.se/web/register](http://www.lascal.se/web/register)